

# DS12DL & DS12DLMB 300mm Disc Sanders



Axminster Tool Centre,  
Unit 10 Weycroft Avenue, Axminster, Devon EX13 5PH

**axminster.co.uk**

# Index of contents

---

Index of Contents	02
Declaration of Conformity	02
What's Included	03
General Instructions for 230V Machines	04
Specific to Sanding Machines	05
Specification	06
Assembly	06
Identification and Description	07
Setup/Adjustments	08-09
Changing the Sanding Disc	10-11
Maintenance	11
Troubleshooting	11
Parts List/Breakdown	12-13
Wiring Diagram	14
Notes	15

## Declaration of Conformity

---

### Copied from CE Certificate

The undersigned, George N. Sifonios authorised by

META INTERNATIONAL CO., LTD. NO. 38-46, YA TAN Rd., TA YA HSIANG. TAICHUNG HSIEN, TAIWAN, R.O.C.

### Model Number WD-12 (Sander)

Manufactured by META INTERNATIONAL CO., LTD. is in compliance with the standards determined in the following Council Directive.

Applicable Directive:

**2006/42/EC**

Applicable Standards:

**EN ISO 12100-1:2003+A1:2009,  
EN ISO 12100-2:2003+A1:2009**



## Warning

The symbols below advise that you follow the correct safety procedures when using this machine.



Fully read manual and safety instructions before use



Ear protection should be worn



Eye protection should be worn



Dust mask should be worn



**HAZARD**  
Motor gets hot

## What's Included

Quantity	Item	Part	Model Number
1 No	DS12DL-DS12DLMB 300mm Disc Sander	<b>A</b>	<b>WD-12</b>
1 No	Mitre Fence	<b>B</b>	
1 No	10-13mm spanner	<b>C</b>	
1 No	Bag Containing Handle and two Phillips Screws	<b>D</b>	
1 No	Instruction Manual		

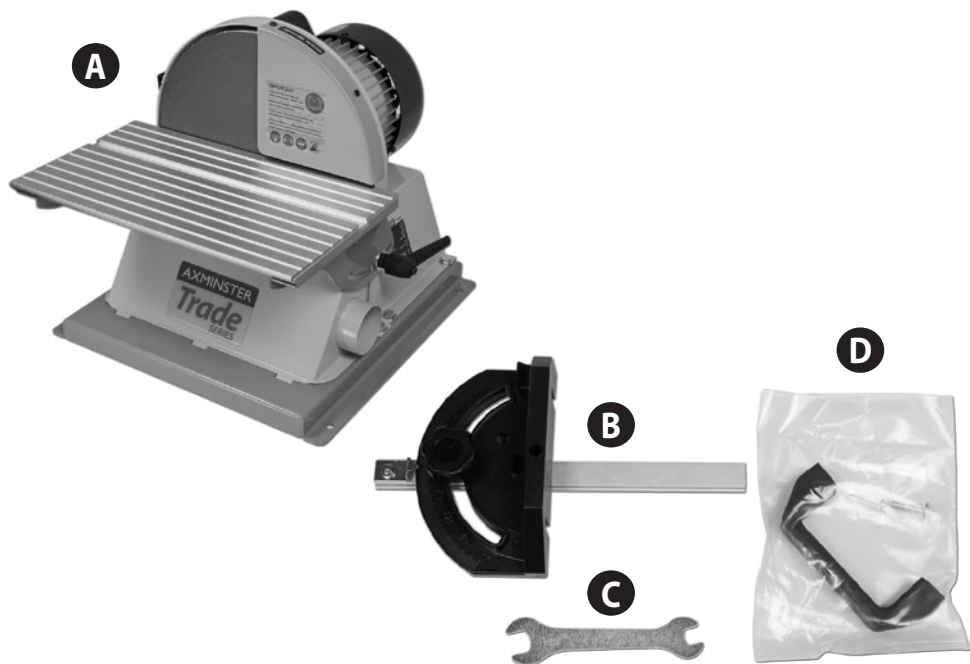

**NOTE: Please read the Instruction Manual prior to using your new machine; as well as the operating procedures for your new machine, there are numerous hints and tips to help you to use the machine safely and to maintain its efficiency and prolong its life.**

Having opened the box, remove all the components stowed in the packaging. Place these carefully to one side.

Remove the top packaging and lift the machine out of the box and place upon a clear flat surface, taking care not to trap or pinch the power cable under the chassis.

Remove any other items from the box.

**Having unpacked your sander and its various components, if you do not wish to retain the packaging please dispose of it responsibly, especially any polystyrene; most of the rest of the packaging is biodegradable.**

Keep this Instruction Manual readily accessible for any others who may also be required to use the machine.

# General Instructions for 230V Machines

## Good Working Practices/Safety

The following suggestions will enable you to observe good working practices, keep yourself and fellow workers safe and maintain your tools and equipment in good working order.



**WARNING! KEEP TOOLS AND EQUIPMENT OUT OF THE REACH OF YOUNG CHILDREN!**

## Mains Powered Tools (General) /Disc & Belt Sander

### Primary Precautions

These machines are supplied with a moulded 13 Amp. Plug and 3 core power cable. Before using the tool inspect the cable and the plug to make sure that neither are damaged. If any damage is visible have the tool inspected/repared by a suitably qualified person. If it is necessary to replace the plug, it is preferable to use an 'unbreakable' type that will resist damage on site.

Only use a 13 Amp plug, make sure the cable clamp is tightened securely. Fuse at 5 Amp. It is also good practice to use switched outlets. If extension leads are to be used, carry out the same safety checks on them, and ensure that they are correctly rated to safely supply the current that is required for your machine.

This machine is intended primarily for inside/workshop usage.

### Work Place/Environment

Always mount the machine on a flat, level stable surface. There are several methods of achieving this, bolting the machine directly to a 'good solid workbench', bolting the machine to a sturdy base board that can be clamped to the 'good solid workbench'; create an independent entity by bolting the machine to its own stand.

However when you mount your machine, make sure it is fastened down and stable before use.

Paper belts and discs do not respond well to wet or damp conditions. In the worst case the adhesives holding the belt and the abrasive fail completely, the belts fall apart and the abrasive becomes a soggy mess against the edge of your work piece.

Try to keep the machine in a reasonably dry, warm environment. If this is not possible; or if the machine is to remain unused for some time, at least remove the belt, put in a 'plastic' bag (your partner will take a dim view of sawdust trails) and store in a warm dry place.

I'm afraid I can offer no suggestions for the disc, unless you have upgraded to some form of 'velcro' fastening method, in which case, do the same as with the belt.

(P.S. don't forget... don't leave the spare belts/discs in the damp). Keep the work area as uncluttered as is practical, this includes personnel as well as material.



**UNDER NO CIRCUMSTANCES SHOULD CHILDREN BE ALLOWED IN WORK AREAS!**



**WARNING! THE SANDING DISC CANNOT BE DECLUTCHED FROM THE BELT AND VICE VERSA, BOTH FUNCTIONS ARE ACTIVE WHEN THE MACHINE IS RUNNING. REMEMBER THIS, AND DO NOT LEAVE LOOSE OBJECTS OF ANY DESCRIPTION, ON THE MACHINE IF IT IS GOING TO BE USED!**

## Specific to Sanding Machines

Once the sander is mounted, carry out any setting operations, (mitre, tilt...?), and remove all tools used in the setting operations (if any) and place safely out of the way. If you are working long lengths of material arrange for extra support beyond the boundary of the machine, and check you have sufficient room to manoeuvre the material through all the operations you will wish to carry out.

It is good practice to leave the machine unplugged until work is about to commence, also make sure to unplug the machine when it is not in use. Always disconnect by pulling on the plug body and not the cable.

After fitting a new sanding disc, it is good practice to lightly sand across the left side of the disc with a reasonable sized (20mm x 50mm) piece of timber to make sure the sanding disc is correctly 'seated' on the disc. The sanding action will press the sanding disc firmly back against the disc itself.

It is not good practice to wear gloves whilst sanding as one tends to lose the 'feel' of the work piece/sander contact, but obviously this removes the safety barrier between your fingers and the sanding surface. Remain focused and exercise caution whilst sanding.

**DO NOT** sand very small pieces of work with bare hands; try to construct some form of holder.

**MAKE SURE** you are comfortable before you start work, balanced, not reaching etc. If the work you are carrying out is liable to generate excessive grit or dust or chips, wear the appropriate safety clothing, goggles, masks etc., If the work operation appears to be excessively noisy, wear ear-defenders. If you wear your hair in a long style, wearing a cap, safety helmet, hair net, even a sweatband, will minimise the possibility of your hair being caught up in the rotating parts of the machine, likewise, consideration should be given to the removal of rings and wristwatches, if these are liable to be a 'snag' hazard.

**DO NOT** work with cutting/abrasive tools of any description if you are tired, your attention is wandering or you are being subjected to distraction. A deep graze, a lost fingertip or worse, is not worth it!

**DO NOT** use the machine within the designated safety areas of flammable liquid stores or in areas where there may be volatile gases. There are very expensive, very specialised machines for working in these areas, **THIS IS NOT ONE OF THEM.**

**CHECK** that sanding surfaces are still sufficiently abrasive to carry out the work you intend. Sanding belt cleaning sticks are an efficient method of prolonging the life of the belts and discs, and will also maintain their operating performance.

**CHECK** that the belts or discs are undamaged; torn edges can pick up on the work piece and will cause the medium to tear, often very rapidly with accompanying sharp flapping edges.

**ALWAYS** offer the work piece to the belt/disc so that the motion carries the work against the restraining surface, (i.e. the work stop or the table, (use the left hand side of the disc).

**DO NOT** press too heavily against the sanding surface, all this will do is slow the sander down. Remember, sanders work by removing small particles of material quickly and heavy pressure works adversely to the cutting process, further, it will accelerate the rate of 'clogging' of the abrasive surfaces, rendering the machine less efficient.

If you are attempting to sand inside curves (over the 'tracking drum') do not press at all, other than to keep the work piece in contact with the surface, any pressure could upset the tracking geometry. As there is no cushioning effect to the belt passing around the drum, expect an added vibration and compensate for it.

Sanding of certain types of timber may make the fitting of dust extraction mandatory in order to comply with the directives of the HSE. However, even if it is not mandatory, it is strongly recommended that you consider fitting dust extraction. It will certainly reduce the level of dust and grit, and as it helps to remove the waste quicker, will certainly prolong the longevity of the abrasive.

Above all, **OBSERVE....** make sure you know what is happening around you, and **USE YOUR COMMON SENSE.**

# Specification

Code	<b>501210</b>
Model	<b>DS12DL</b>
Rating	<b>Trade</b>
Power	<b>560W (230V)</b>
Speed	<b>1,425rpm</b>
Diameter of Disc	<b>305mm</b>
Table Size	<b>400 x 225mm</b>
Table Tilt	<b>45°</b>
Dust Extraction Outlet	<b>63mm</b>
Overall L x W x H	<b>530 x 410 x 410mm</b>
Weight	<b>28kg</b>

Code	<b>505092</b>
Model	<b>DS12DLMB</b>
Rating	<b>Trade</b>
Power	<b>560W (230V)</b>
Speed	<b>1,425rpm</b>
Diameter of Disc	<b>305mm</b>
Table Size	<b>400 x 225mm</b>
Table Tilt	<b>45°</b>
Dust Extraction Outlet	<b>63mm</b>
Overall L x W x H	<b>530 x 410 x 410mm</b>
Weight	<b>28kg</b>

# Assembly

In order to reduce the footprint of the machine for packaging, several items are dismantled from the machine and needs to be re-affixed.

**Step 1** Locate the plastic bag (D) containing the handle and the two Phillips screws, line up the pre-drilled holes in the handle with threaded holes to the rear of the sander and secure using the two Phillips screws (See figs 1-2).

**Fig 01-02**

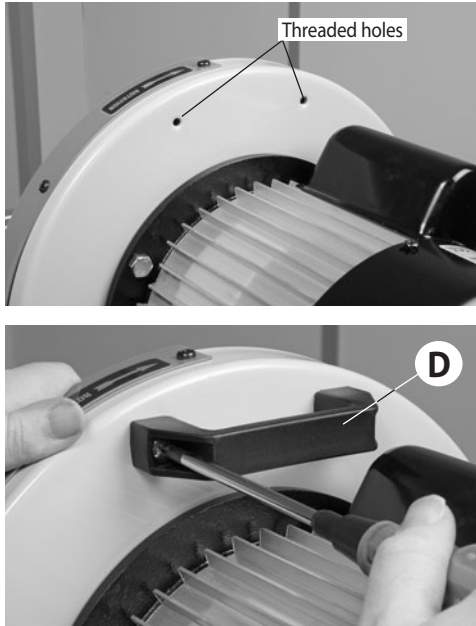

**Step 2** Locate the mitre fence (B) and slide it into the tables 'T' slot from the right side (See fig 3).

**Fig 03**



Disc sander assembled

# Identification and Description

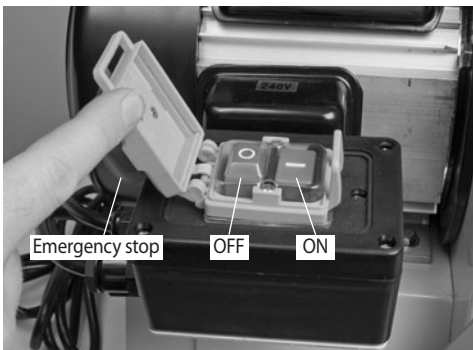
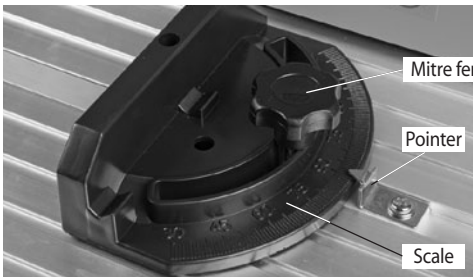
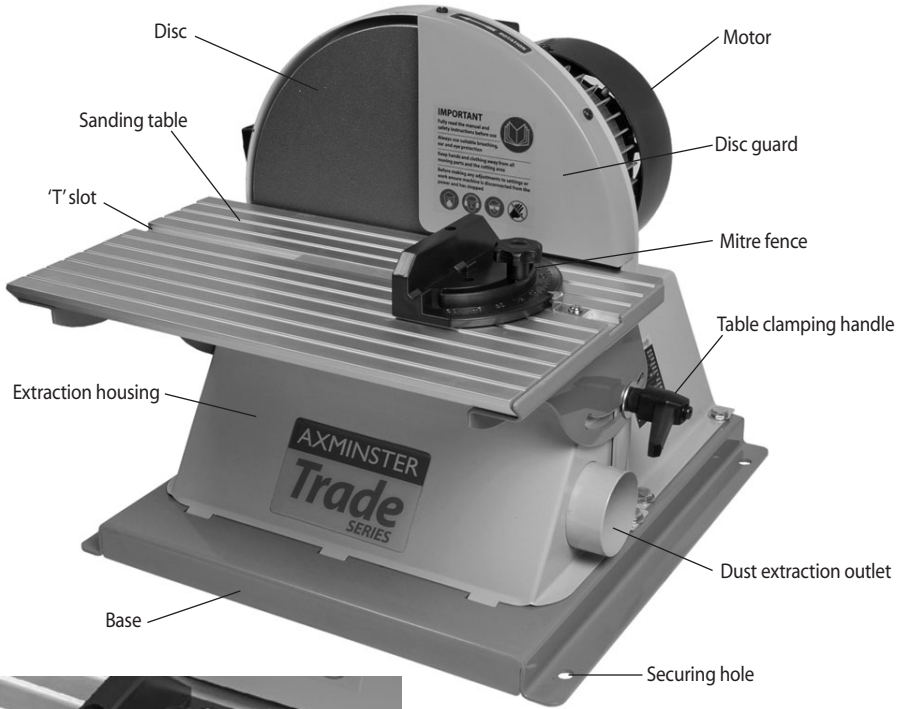

NVR Switch

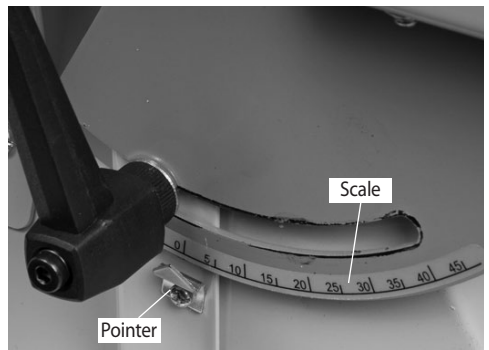



# Setup/Adjustments

## Setting the table clearance

The gap between the table and the disc should be set to a maximum of 1.6mm to clear the debris and to ensure sufficient support for the timber.

The table should be positioned so that sanding only occurs from downward movement of the disc face. Small pieces of timber should not be disc sanded. **A responsible person should check the setting of the machine before use.**

**Step 1** To set the table clearance, first remove the guard by undoing the two Phillips screw (a), place screws and guard safely aside (see fig 01).

**Fig 01**

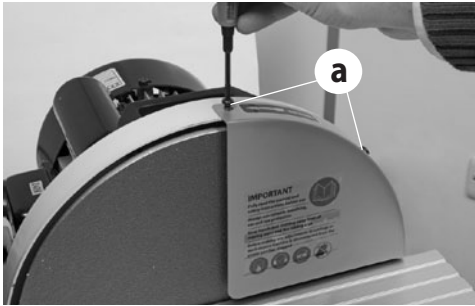

**Fig 02**

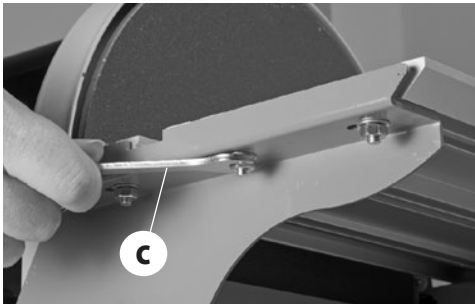

**Step 2** Locate the supplied spanner (C) loosen the six nuts beneath the table brackets, (see fig 02) place a rule up against the sanding disc and adjust the table until there is a 1.6mm clearance between the table and the disc, (see fig 03).

**Step 3** Replace the disc guard as described above.

**Step 4** Place the 90° square against the disc and mitre fence, (see fig 04) to check the table is square then tighten the six nuts beneath the table.

**Fig 03**



Place a rule up against the sanding disc and adjust the table until there is a clearance of 1.6mm.

**Fig 04**



**NOTE: MAKE SURE THE MITRE FENCE IS SET TO ZERO ON THE SCALE!**

**Step 5** Place the square upright against the sanding disc, loosen the two clamping handles (b) on either side of the table and adjust the table's angle, until it's perpendicular to the sanding disc (see fig 05). Tighten the clamping handles.

**Fig 05**

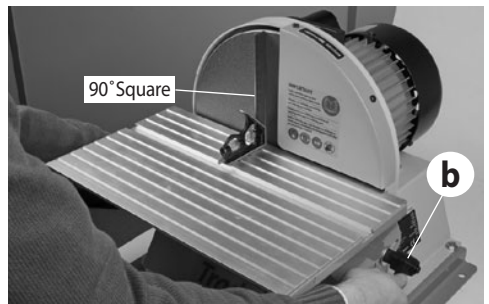



**Step 6** Check the pointer is set to **ZERO** on the tables scale and adjust until correct (see fig 6).

**Fig 06**

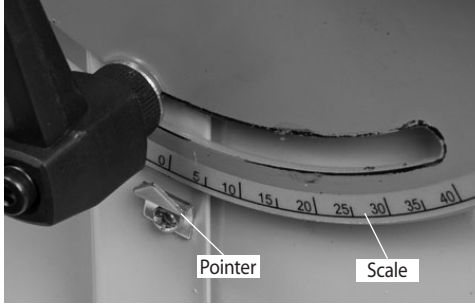

## Securing the Sander

It is recommended to secure the sander to a work bench or stand using the four pre-drilled holes (d) in the chassis, (see fig 07).

**Fig 07**



## Operating Instructions



**WARNING! KEEP TOOLS AND EQUIPMENT OUT OF THE REACH OF YOUNG CHILDREN!**



**CLEAR ALL TOOLS AWAY FROM SANDING AREA!**



**WARNING! WEAR EYE AND EAR PROTECTION!**



**WARNING! WEAR A DUST MASK!**



**CONNECT THE SANDER TO THE MAINS AND SWITCH ON.**

Don't press too heavily against the sanding surface, all this will do is slow the sander down. Remember, sanders work by removing small particles of material quickly and heavy pressure works adversely to the cutting process, further, it will accelerate the rate of 'clogging' of the abrasive surfaces, rendering the machine less efficient.

## Sanding Configurations

### Disc Sanding

**Fig 08**



### Bevel Sanding

**Fig 09**



# Changing the Sanding Disc



**DISCONNECT THE SANDER FROM THE MAINS SUPPLY BEFORE CONTINUING!**

**Fig 10**



**Step 1** Remove the two table clamping handles (see fig 10).

**Fig 11**



**Step 2** Remove both Phillips screws on either side of the table and place safely aside (see fig 11).

**Fig 12**



**Step 3** Lift the table assembly away and place to one side (see fig 12).

**Fig 13**



**Step 4** Locate the supplied spanner (C) and using the 10mm end remove the two nuts on either side of the extraction housing (see fig 13)

**Fig 14**

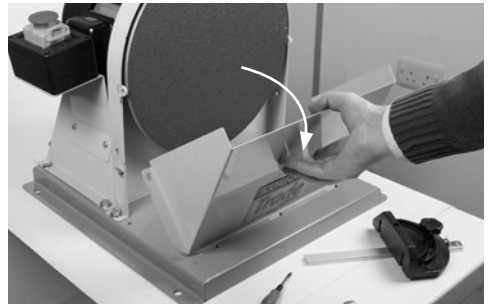

**Step 5** Lower the extraction housing (see fig 14).

**Fig 15**



**Step 6** Grip the edge of the adhesive disc and peel away from the plate; turning the plate as required to free the entire disc (see fig 15). Clean the surface of the disc with a de-greasing cleaner. Allow to dry off and wipe over with a

## Changing the Sanding Disc

clean dry cloth. Locate the sanding disc, peel the cover from the adhesive surface and apply **CAREFULLY** to the disc (see fig 16). Use a piece of cloth in your hand or wear a glove, to firmly press the abrasive to the disc, the application will be reinforced by a gentle sanding action across the face when you first use the new sanding disc.

**Step 7** Re-assemble the sander as described opposite but in reverse (see figs 10 to 14).

Fig 16



Turn the disc while applying pressure

## Maintenance



**RECONNECT THE SANDER TO THE MAINS SUPPLY AND CONTINUE WITH OPERATION.**



**DISCONNECT THE SANDER FROM THE MAINS SUPPLY BEFORE CONTINUING!**

There is very little mechanical maintenance that can be carried out on the machine. Most prudent maintenance is preventative and concerned with keeping the machine clean.

1. At reasonable intervals, inspect and remove all dust/resin build ups, and blow the motor clean.
2. Remove the table assembly and lower the extraction housing, clean any dust or resin build up. Re-assemble the sander.

3. Inspect the sanding disc for signs of wear and tear and replace if necessarily.

4. From time to time using a damp cloth wipe over the sanders surface.

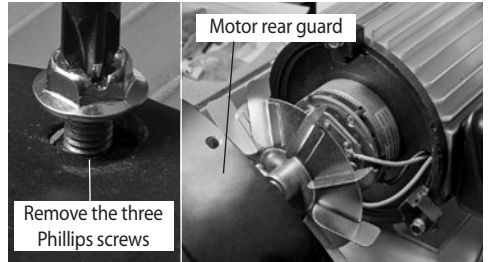

Remove the rear guard and blow the motor clean

## Troubleshooting

TROUBLE	PROBABLE CAUSE	REMEDY
<b>Motor does not run when power switch is pressed "ON"</b>	1. Switch is burnt out 2. Connection wire is loose or damaged	1. Replace the switch 2. Tighten wire or replace
<b>Motor does not run at full speed</b>	1. Power voltage is too low 2. Motor is damaged.	1. Test voltage 2. Check and repair motor
<b>Motor does not reach full power</b>	1. Incorrect power wiring 2. Overloaded	1. Replace with the correct size of power wiring 2. Reduce load
<b>Motor overheating</b>	1. Motor voltage is different 2. Motor is damaged	1. Check the voltage label 2. Check and repair the motor

## Parts List/Breakdown

PART NO	DESCRIPTION	SPECIFICATION	Q'TY
1	Base		1
2	Motor Base		1
3	Motor	3/4 HP	1
4	Disc Cover		1
5	Disc	12"	1
6	Sanding Paper	12"	1
7	Left Tilting Turing		1
8	Right Tilting Turning		1
9	Table	Aluminum	1
10	Dust Hood Cover		1
11	Handle	M8x16	2
12	Pointer		1
13	Hex. Head Screw	M4x8	1
14	Washer	M6	2
15	Pan Head Screw	M6x8	2
16	Pan Head Screw	M8x12	6
17	Washer	M8	6
18	Pan Head Screw	M8x25	4
19	Pan Head Screw	M8x20	2
20	Washer	M8x18	4
21	Nut	M8	4
22A	Switch	UL	1
22B	Switch	CE	1
23	Power Cord		1
28	Pan Head Screw	M6x20	6
29	Washer	M6x13	6
30	Nut	M6	6
31	Mitre Bar		1
32	Mitre Gauge		1
33	Bolt	1/4"	1
34	Pointer		1
35	Hex. Head Screw	3/16"x3/8"	1
36	Pin	5x20	1
37	Spanner		1
38	Open End Wrench	10~13mm	1
39	Handle		1
40	Hex. Head Screw	M6x20	2
41	Safety Guard		1
42	Pan. Head Screw	5x8	2

# Parts List/Breakdown

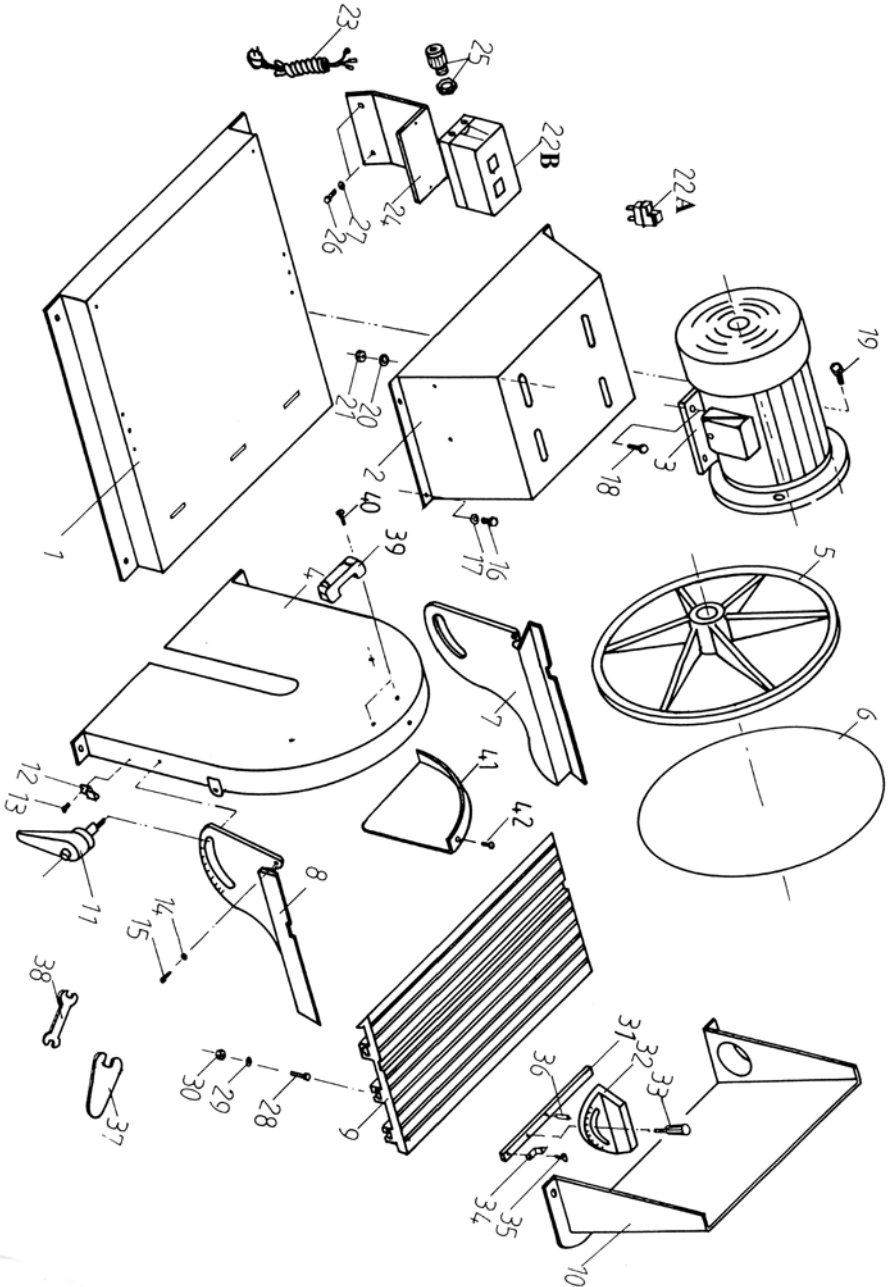

# Wiring Diagram

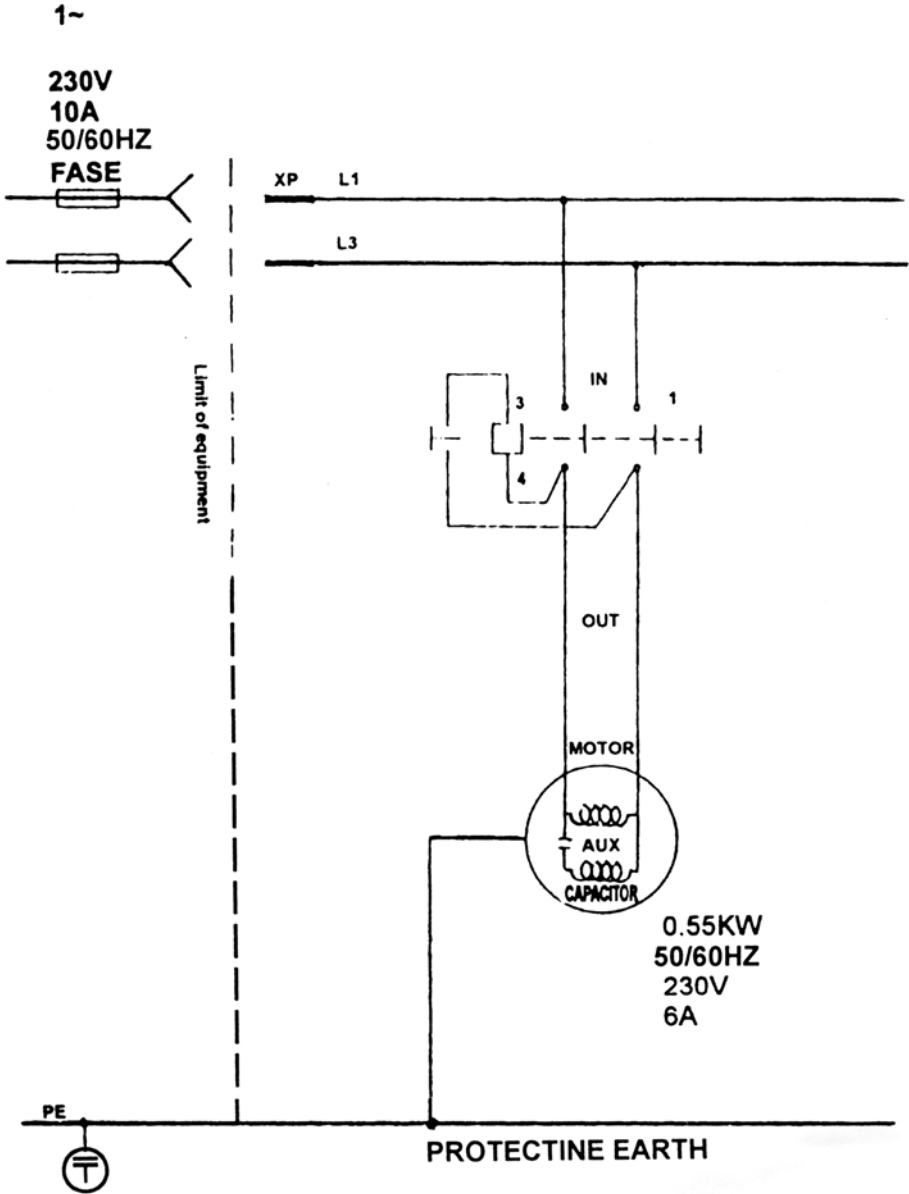







Please dispose of packaging for the product in a responsible manner. It is suitable for recycling. Help to protect the environment, take the packaging to the local recycling centre and place into the appropriate recycling bin.

**Only for EU countries**



Do not dispose of electric tools together with household waste material. In observance of European Directive 2002/96/EC on waste electrical and electronic equipment and its implementation in accordance with national law, electric tools that have reached the end of their life must be collected separately and returned to an environmentally compatible recycling facility.